

Performance Specification for battery type BA-052 (=2 batteries)

Battery dimensions (mm)

Nominal Voltage	12 Volts
Nominal Capacity	
at 20 hour rate (1,35 A to 10,5 Volts)	27 Ah
at 10 hour rate (2,44 A to 10,5 Volts)	24,4 Ah
at 5 hour rate (4,42 A to 10,2 Volts)	22,1 Ah
at 1 hour rate (15,7 A to 9,0 Volts)	15,7 Ah
Dimension (mm)	Length=166, Width=175, Height=125
Approximate weight	9,0 kg
Energy Density	89,2 Wh/l
Specific Energy	36 Wh/kg
Internal Resistance (Fully charged battery)	7 mΩ
Maximum discharge current in 1 minute discharge	162 A
Maximum discharge current in 5 seconds discharge	405 A
Recommended charging tension (temperature=20°C)	
floating use: 13,5-13,8 V	cyclic use: 14,4-15,0 V
Thermal compensation factor	
floating use: -18mV/°C	cyclic use: -30mV/°C
Maximum charging current	6,75 A
Terminals	Bolt and Nut M5
Vibration Test (2000 cycles/minute, 2,55 mm excursion, 2 hours)	No loss in capacity or performance
Shelf life - % of nominal capacity at 20°C	
1 month	97%
3 months	91%
6 months	83%
Storage temperature	-20°C to 40°C
Operative temperature Range	
Charge	0°C to 40°C
Discharge	-20°C to 50°C
Case material	Acrylonitrile-Butadiene-Styrene
	Standard Case: According to UL-94 HB
	Also Available: According to UL-94V0
Life expectancy (Stand-by)	3 to 5 years according to Eurobat standards

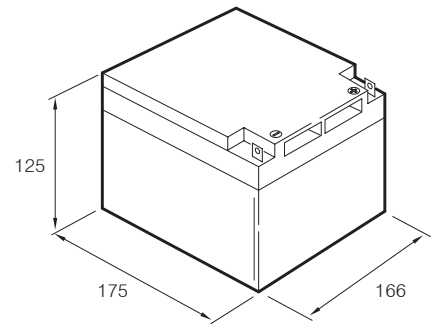

Terminal type

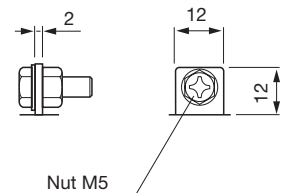

Constant Power Discharge Table (Watt)

Time	5'	10'	15'	20'	30'	45'	1h	2h	3h	5h	10h	20h
1,8V/Cell	660,4	514,8	423,9	362,3	283,2	215,7	175,3	102,2	73,0	47,0	25,4	13,7
1,75V/Cell	706,6	539,0	439,4	373,2	289,7	219,4	177,8	103,3	73,8	47,6	25,9	14,1
1,7V/Cell	756,1	564,4	455,5	384,5	296,3	223,2	180,4	104,5	74,6	48,2	26,4	14,5
1,65V/Cell	781,7	577,2	463,2	389,6	298,9	224,3	180,9	104,3	74,4	48,1	26,4	14,6
1,6V/Cell	808,2	590,3	471,1	394,8	301,5	225,4	181,3	104,1	74,2	47,9	26,3	14,6

Constant Current Discharge Table (Ampere)

Time	5'	10'	15'	20'	30'	45'	1h	2h	3h	5h	10h	20h
1,8V/Cell	78	48	39	33	24	19,3	15,6	9,8	6,9	4,5	2,46	1,41
1,75V/Cell	86	53	42	34	25	20,2	16,3	10,2	7,1	4,6	2,54	1,42
1,7V/Cell	95	59	44	36	27	21,1	16,9	10,5	7,3	4,7	2,62	1,42
1,65V/Cell	96	59	45	37	27	21,3	17,1	10,6	7,4	4,8	2,65	1,43
1,6V/Cell	97	60	45	37	27	21,5	17,2	10,7	7,4	4,8	2,67	1,43

Discharge time vs. discharge current

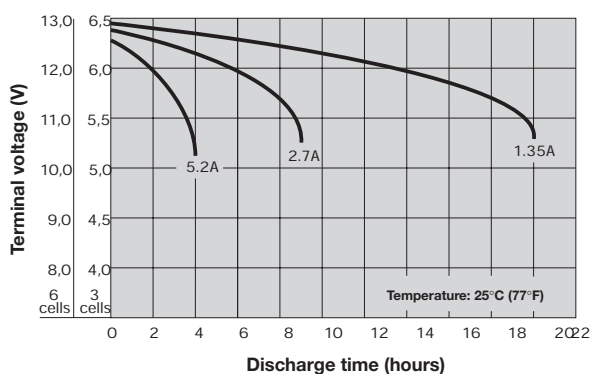

Discharge time vs. discharge current

